

AWWA C-509 GATE VALVE WITH BOX TO
BE OPEN LEFT

TAPPING SLEEVE TO BE STAINLESS STEEL
(NO OTHER ACCEPTED)

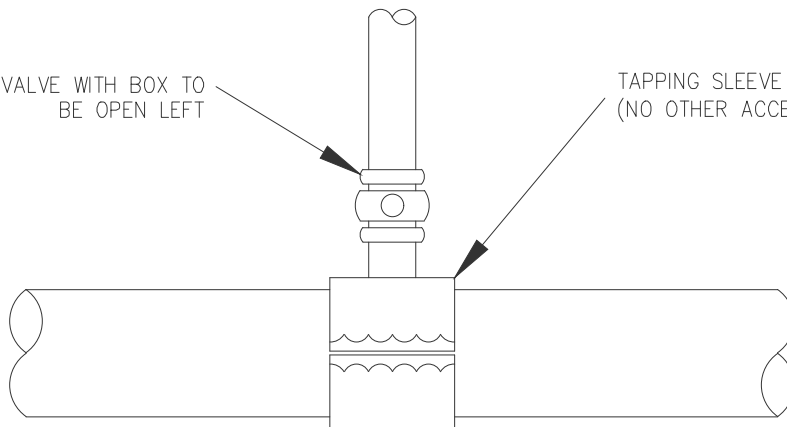

TOP VIEW

3" DIAMETER OR GREATER
TAPPING SLEEVE & VALVE ASSEMBLY

NOTES:

1. TAPPING SLEEVE SHALL BE ROMAC SSTIII, SMITH-BLAIR 665, OR APPROVED EQUAL.
2. GATE VALVE INSTALLATION SHALL COMPLY WITH DETAIL W-12.
3. PIPE COUPON SHALL BE PROVIDED TO INSPECTOR.
4. SIZE ON SIZE TAPS ARE NOT ALLOWED ON R.C.C.P. OR AC PIPE.
5. THRUST BLOCKING REQUIRED BEHIND TAPPING SLEEVE.
6. TAPPING SLEEVE SHALL BE AIR TESTED PRIOR TO MAKING THE TAP.



WATER CONSTRUCTION DETAILS
TAPPING SLEEVE AND VALVE ASSEMBLY

REVISION DATE:
2/1/2024

SHEET: W-02