

UNPAVED AND FUTURE PAVED AREAS

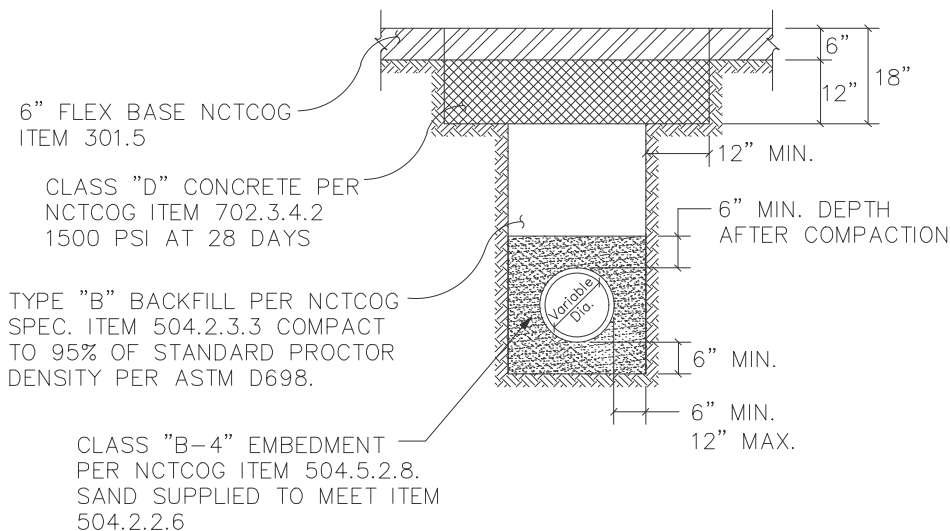

EXISTING FLEXBASE SURFACE

NOTES:

1. AT THE END OF EACH WORK DAY ALL SPOILS SHALL BE REMOVED FROM THE CITY & TXDOT R.O.W. UNLESS PRIOR WRITTEN PERMISSION IS OBTAINED FROM THE OWNER TO STORE SPOILS IN DESIGNATED SPOIL STORAGE AREAS THAT DO NOT OBSTRUCT AUTOMOBILE OR PEDESTRIAN TRAFFIC.
2. ALL BACKFILL SHALL BE PER NCTCOG SPEC. ITEM 504 AND SHALL BE COMPACTED PER NCTCOG SPEC ITEM 504.5.3.2. ROCKS GREATER THAN 4" IN DIAMETER SHALL BE REMOVED FROM ANY NATIVE MATERIAL USED AS BACKFILL.
3. ALL PAVEMENT SHALL BE REMOVED ALONG NEAT SAW CUT LINES PER NCTCOG SPEC ITEM 402.3.
4. BLUE UNDERGROUND WATER LINE WARNING TAPE OF MIN. 4" WIDTH SHALL BE INSTALLED ABOVE THE EMBEDMENT MATERIAL.
5. A MAXIMUM OF 200- FEET OF OPEN TRENCH WILL BE ALLOWED AT ANY TIME, UNLESS APPROVED BY THE CITY ENGINEER.
6. TOPSOIL SHALL BE 4 INCHES IN DEPTH AND SHALL BE LOOSE AND FREE OF ROCKS OR CLODS GREATER THAN 1/4" IN DIAMETER. ALL TOPSOIL SHALL BE APPROVED BY THE OWNER PRIOR TO INSTALLATION.



WATER CONSTRUCTION DETAILS
STANDARD WATER LINE EMBEDMENT & BACKFILL

REVISION DATE:
2/1/2024

SHEET: W-04