

- LOCATION FOR FUTURE CLEANOUT COVER:
- TURF – USE POP-UP CAP 5141M
 - SIDEWALK/DRIVEWAY – USE STD. FRAME AND COVER 5140M

REFER TO CITY OF KELLER STANDARDS FOR LATERAL CONNECTION TO MAIN

NOTES:

1. NO CONNECTIONS OR FITTINGS ARE ALLOWED ON THE VERTICAL STACK.
2. RESIDENTIAL SEWER LATERAL SHALL BE MINIMUM 4" PVC CLASS 160 SDR 26 AT A 2% MINIMUM GRADE.
3. SEWER LATERALS SHALL EXTEND TO A POINT 10 FT BEYOND RIGHT-OF-WAY LINE AND SHALL BE A MAXIMUM OF 5 FT DEEP.
4. SEWER LATERALS SHALL BE PLACED AT THE ϕ OF EACH LOT.
5. DURING INITIAL LATERAL INSTALLATION, A 4" CLEANOUT SHALL BE BROUGHT 3-4 FT ABOVE GRADE AT THE R.O.W. LINE.
6. PRIOR TO FINAL GRADING, LATERAL LOCATION SHALL BE MARKED ON CURB AND CLEANOUT TO BE CUT 1 FOOT BELOW GRADE.
7. CONNECTION TO THE MAIN SHALL BE MADE WITH A 4"X4"X4" COMBINATION WYE & $\frac{1}{8}$ BEND.
8. ALL JOINTS SHALL BE GLUED.

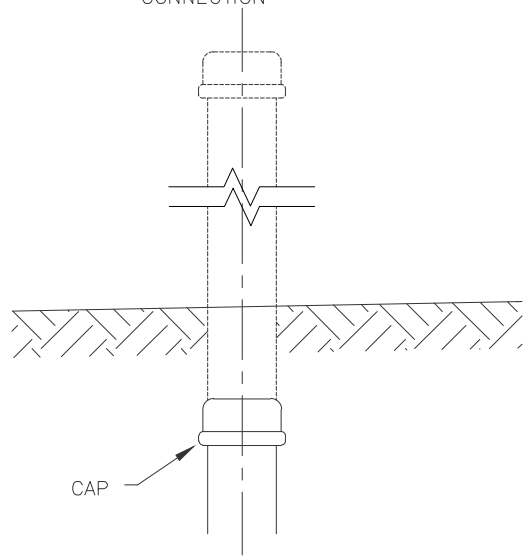

SEWER SYSTEM CONSTRUCTION DETAILS
 SANITARY SEWER MANHOLE SERVICE LINE
 CONNECTION

REVISION DATE:
 2/1/2024

SHEET: S-06