

ALL DISTURBED AREAS SHOULD BE SODDED TO RESIST EROSION (BOTH ENDS). SOD SHALL BE WATERED UNTIL ESTABLISHED

NOTE: UPSTREAM AND DOWNSTREAM GRADING IN ROADWAY DITCH IS PROPERTY OWNER'S RESPONSIBILITY DURING DRIVE APPROACH INSTALLATION.

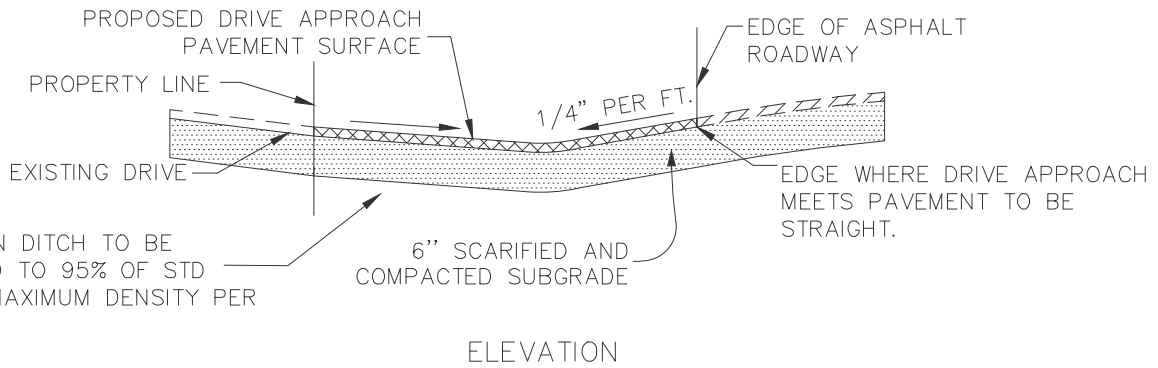

BACKFILL IN DITCH TO BE COMPACTED TO 95% OF STD PROCTOR MAXIMUM DENSITY PER ASTM D698

NOTES:

1. FUTURE MAINTENANCE OF THE DRIVE APPROACH IS THE PROPERTY OWNER'S RESPONSIBILITY.
2. ALL DITCH GRADING UPSTREAM AND DOWNSTREAM OF THE PROPOSED DRIVEWAY IS THE PROPERTY OWNER'S RESPONSIBILITY.
3. DITCH GRADING MUST MATCH NEW LOW WATER CROSSING.
4. ENTIRE DITCH AREA TO BE COVERED WITH GRASS SOD OR BE STABILIZED WITH CURLEX TYPE PRODUCT AND SEEDED BEFORE FINAL CITY INSPECTION ON DRIVE APPROACH IS SCHEDULED.



PAVING CONSTRUCTION DETAILS  
RURAL DRIVE APPROACH WITHOUT CULVERT

REVISION DATE:  
2/1/2024

SHEET: P-14